

THIS DRAWING AND SPECIFICATION, HEREIN, ARE THE PROPERTY OF MARTEL ELECTRONICS AND SHALL NOT BE REPRODUCED OR COPIED OR USED IN WHOLE OR IN PART AS THE BASIS FOR MANUFACTURE OR SALE OF ITEMS WITHOUT WRITTEN PERMISSION

REVISIONS				
ZONE	REV	DESCRIPTION	APPROVED	DATE
	1	PRELIMINARY RELEASE	MAD	10/14/09

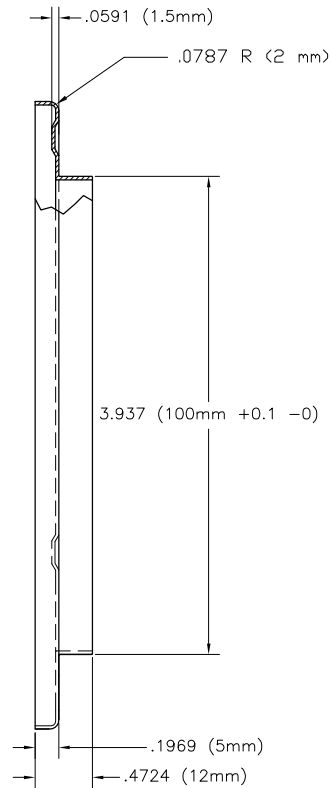
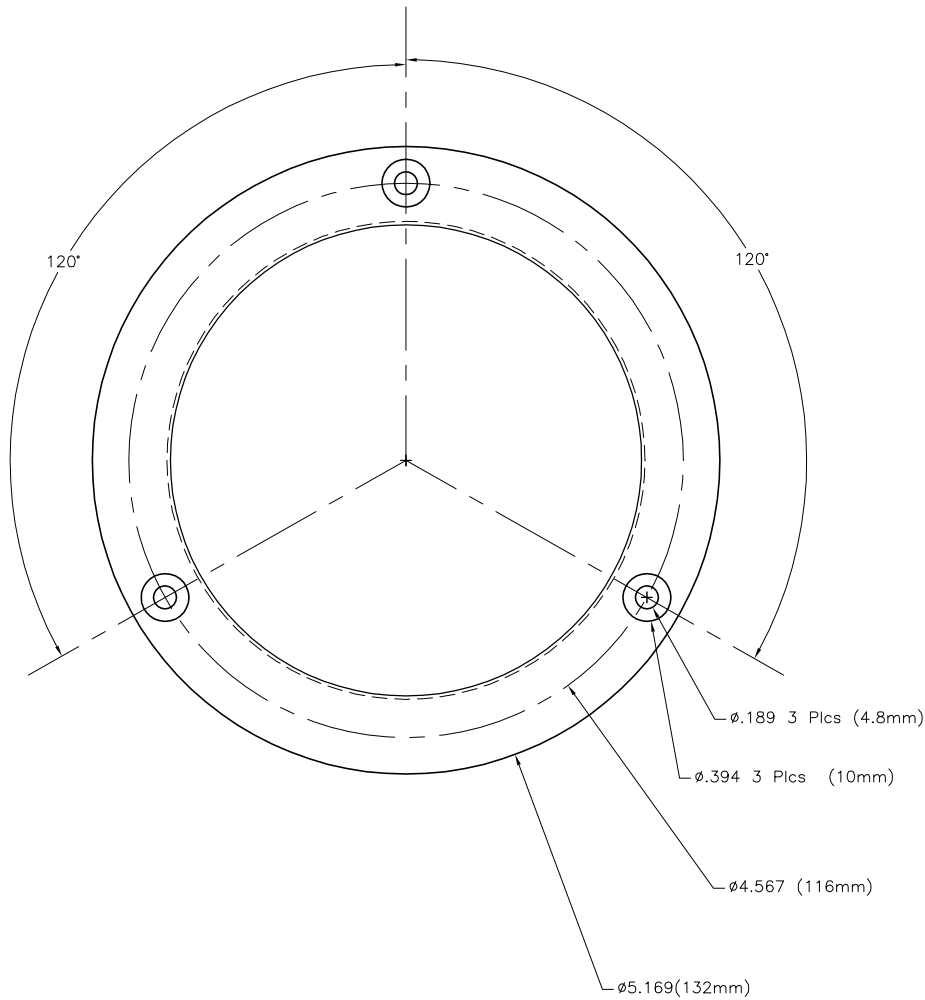

DRAWN BY: MAD	APPROVED BY: -				
MATERIAL: Stainless					
FINISH: Polished		Front Flange, 4" Beta			
TOLERANCES: .XX=±.010 .XXX=±.005 .XXXX=±.0005		SIZE B	PART NO. 80272	DWG NO. 0380272	REV 1
		SCALE 1:1	DATE: 10/14/2009	SHEET 1 of 1	